

FSN021.02

Lavoce

2" FULLRANGE

NEODYMIUM MAGNET
STEEL BASKET DRIVER



- 1 INCH CCAW VOICE COIL
- 83 dB/SPL SENSITIVITY
- 50 WATT PROGRAM POWER HANDLING
- FEM OPTIMIZED MOTOR AND SUSPENSIONS
- VERY LIGHT MEMBRANE, FOR EXTENDED FREQUENCY RESPONSE
- COPPER RING FOR EXTENDED FREQUENCY RESPONSE
- RUBBER SURROUND MATERIAL

GENERAL SPECIFICATIONS

Nominal diameter	mm (in.)	50 (2)
Nominal impedance	Ω	8
Minimum impedance	Ω	6
Program power (1)	W	50
AES Power rating (2)	W	25
Sensitivity (3)	dB	83
Frequency range	Hz	140 ÷ 20000
Voice coil diameter	mm (in.)	25 (1)
Chassis material		Steel
Magnet material		Neodymium
Magnet dimensions	mm (in.)	24,9 x 5 (0.98 x 0.2)
Coil material		CCAW
Former material		Polyimide
Cone material		Aluminium
Surround material		Rubber
Xmax (4)	mm (in.)	2,5 (0.1)
Xmech (5)	mm (in.)	2,7 (0.11)
Gap height	mm (in.)	3 (0.12)
Voice coil winding height	mm (in.)	6,4 (0.25)
Driver displacement volume	l (ft ³)	0,026 (0.001)
Recommended enclosure	l (ft ³)	0,63 (0.022)
Recommended tuning	Hz	Sealed

SMALL SIGNAL PARAMETERS

DC resistance	Re	Ohm	5,7
Resonance frequency	Fs	Hz	151
Moving mass	Mms	g (oz)	1,7 (0.06)
Compliance	Cms	mm/N	0,65
Force factor	BxL	N/A	3,44
Mechanical Q-factor	Qms		5,5
Electrical Q-factor	Qes		0,77
Total Q-factor	Qts		0,68
Equivalent air volume	Vas	l (ft ³)	0,33 (0.01)
Voice coil Inductance	Le	mH	0,1
Diaphragm area	Sd	cm ² (in. ²)	19 (2.9)
Reference efficiency	Eta 0	%	0,14
Efficiency bandwidth product	EBP	Hz	196

SHIPPING INFORMATION

Net weight	kg (lb.)	0,15 (0.33)
Multipack size (60)	mm (in.)	260 x 260 x 137 (10.2 x 10.2 x 5.4)
Multipack weight	kg (lb.)	11,4 (25.2)

FREQUENCY RESPONSE AND IMPEDANCE

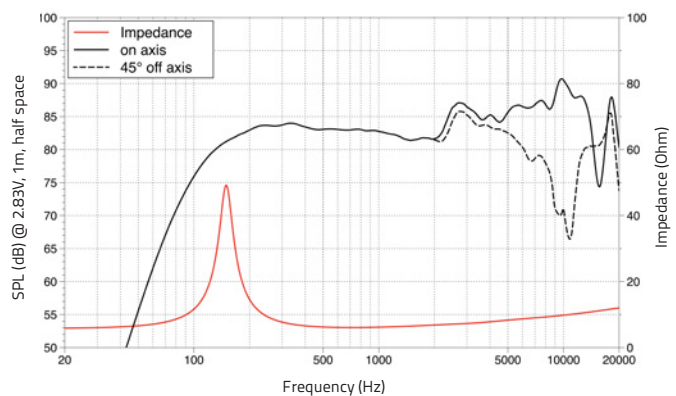

DIMENSIONS mm (in.)

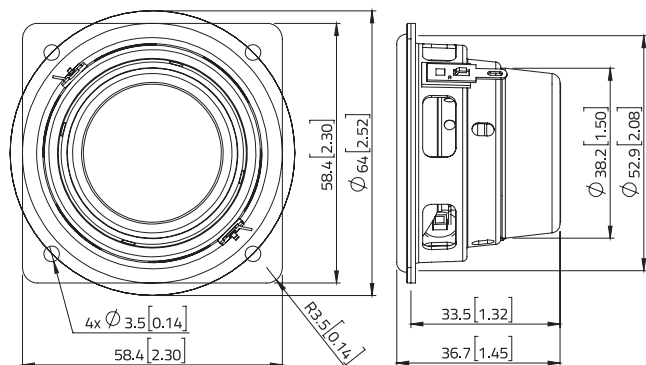

(1) Program power is defined as 3 dB greater than AES Power. (2) Tested for two hours using a continuous, band-limited pink noise signal as per AES 2-1984 Rev. 2003. Loudspeaker tested in free air. (3) From T/S parameters, measured with Klippel DA LPM module. (4) The Xmax is calculated as: $(Hvc - Hg)/2 + Hg/4$. Hvc is the voice coil height and Hg the gap height. (5) The Xmech is calculated as: $(Hvc - Hg)/2 + (Hg - 2)$. Hvc is the voice coil height and Hg the gap height. (6) Thiele-Small parameters are measured after preconditioning: a) at 20°C - 22°C, 50% humidity for 2 hours; b) by Klippel LSI measurement.

All specifications subject to change without notice_E.a

WWW.LAVOCESPEAKERS.COM



Lavoce Italiana

sales@lavocespeakers.com sales.cn@lavocespeakers.com