

FSN020.71F

Lavoce

2" FULLRANGE

NEODYMIUM MAGNET
STEEL BASKET DRIVER



- 0.75 INCH CCAW VOICE COIL
- 86 dB/SPL SENSITIVITY
- 30 WATT PROGRAM POWER HANDLING
- FEM OPTIMIZED MOTOR AND SUSPENSIONS
- COPPER RING FOR EXTENDED FREQUENCY RESPONSE
- RESONANCE FREE AND HEAVY DUTY STEEL BASKET DESIGN
- FLAT BASKET FLANGE FOR EASY MOUNTING

GENERAL SPECIFICATIONS

Nominal diameter	mm (in.)	50 (2)
Nominal impedance	Ω	8
Minimum impedance	Ω	6,9
Program power (1)	W	30
AES Power rating (2)	W	15
Sensitivity (3)	dB	86
Frequency range	Hz	200 ÷ 20000
Voice coil diameter	mm (in.)	20 (0.75)
Chassis material		Steel
Magnet material		Neodymium
Magnet dimensions	mm (in.)	19 x 5 + 19 x 3 (0.75 x 0.2 + 0.75 x 0.1)
Coil material		CCAW
Former material		Polyimide
Cone material		Water Resistant Treated Paper
Surround material		Polycotton
Xmax (4)	mm (in.)	2,4 (0.09)
Xmech (5)	mm (in.)	2,6 (0.1)
Gap height	mm (in.)	3 (0.12)
Voice coil winding height	mm (in.)	6,2 (0.24)
Driver displacement volume	l (ft ³)	0,028 (0.001)
Recommended enclosure	l (ft ³)	1,0 (0.035)
Recommended tuning	Hz	Sealed

SMALL SIGNAL PARAMETERS

DC resistance	Re	Ohm	6,4
Resonance frequency	Fs	Hz	212
Moving mass	Mms	g (oz)	1,17 (0.04)
Compliance	Cms	mm/N	0,482
Force factor	BxL	N/A	3,24
Mechanical Q-factor	Qms		6,36
Electrical Q-factor	Qes		0,95
Total Q-factor	Qts		0,82
Equivalent air volume	Vas	l (ft ³)	0,205 (0.01)
Voice coil Inductance	Le	mH	0,062
Diaphragm area	Sd	cm ² (in. ²)	17,35 (2.7)
Reference efficiency	Eta 0	%	0,20
Efficiency bandwidth product	EBP	Hz	223

SHIPPING INFORMATION

Net weight	kg (lb.)	0,15 (0.34)
Multipack size (60)	mm (in.)	440 x 397 x 182 (17.3 x 15.6 x 7.2)
Multipack weight	kg (lb.)	12,9 (28.5)

FREQUENCY RESPONSE AND IMPEDANCE

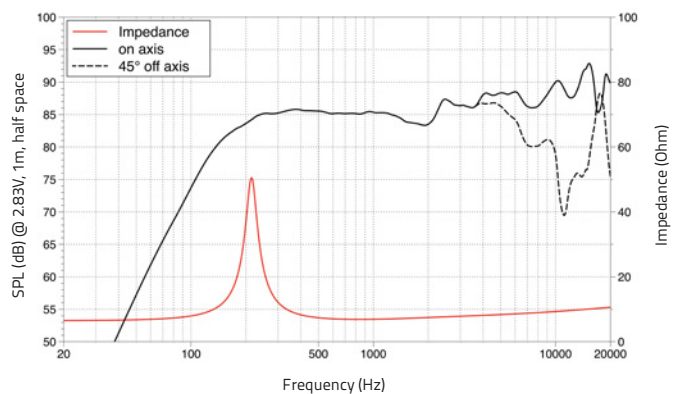

DIMENSIONS mm (in.)

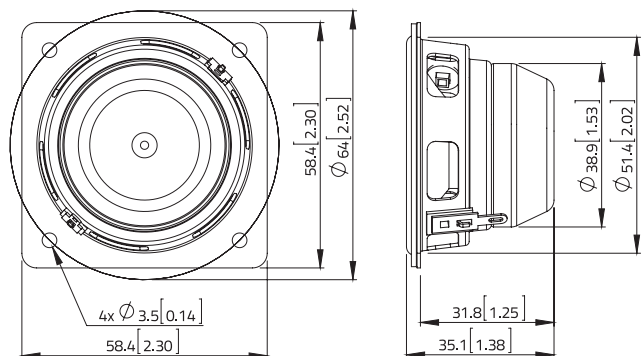

(1) Program power is defined as 3 dB greater than AES Power. (2) Tested for two hours using a continuous, band-limited pink noise signal as per AES 2-1984 Rev. 2003. Loudspeaker tested in free air. (3) From T/S parameters, measured with Klippel DA LPM module. (4) The Xmax is calculated as: $(Hvc - Hg)/2 + Hg/4$. Hvc is the voice coil height and Hg the gap height. (5) The Xmech is calculated as: $(Hvc - Hg)/2 + (Hg - 2)$. Hvc is the voice coil height and Hg the gap height. (6) Thiele-Small parameters are measured after preconditioning: a) at 20°C - 22°C, 50% humidity for 2 hours; b) by Klippel LSI measurement.

All specifications subject to change without notice_E.a

WWW.LAVOCESPEAKERS.COM



Lavoce Italiana

sales@lavocespeakers.com sales.cn@lavocespeakers.com