

HD1003

Lavoce

1" THROAT ENTRY HORN

OEM only

- 90° x 40° NOMINAL COVERAGE
- CUT-OFF FREQUENCY 1000 Hz
- ALUMINIUM CONSTRUCTION TO ENSURE HIGH MECHANICAL STRENGTH AND HEAT DISSIPATION
- FEM OPTIMIZED EXPONENTIAL FLARE

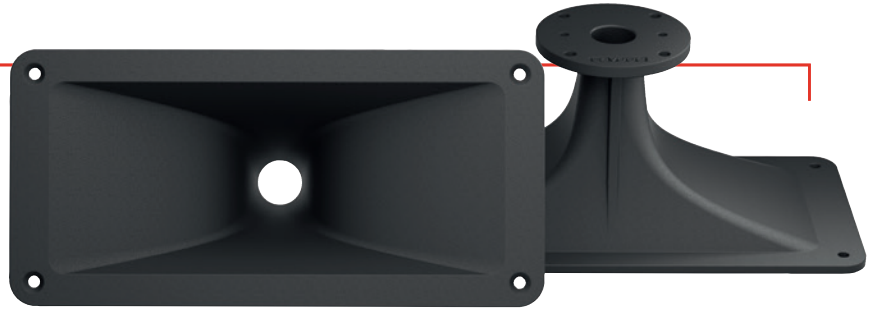

GENERAL SPECIFICATIONS

Throat diameter	mm (in.)	25 (1)
Horizontal nominal coverage	°	90
Vertical nominal coverage	°	40
Cutoff Frequency	Hz	1000
Material	Aluminium	

SHIPPING INFORMATION

Net weight	kg (lb.)	0,5 (1.1)
Multipack size (18)	mm	614 x 502 x 238
W x D x H	(in.)	(24.2 x 19.8 x 9.4)
Multipack weight	kg (lb.)	12,5 (27.5)

DIMENSIONS mm (in.)

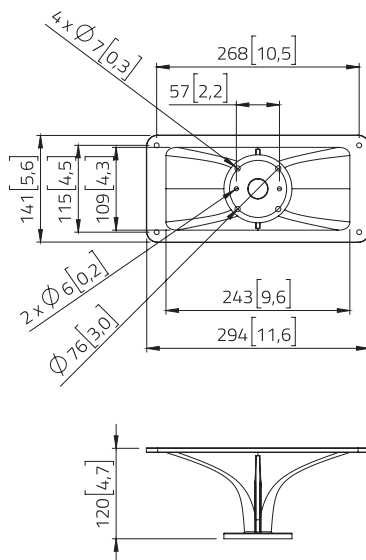

HORIZONTAL ANGLE*

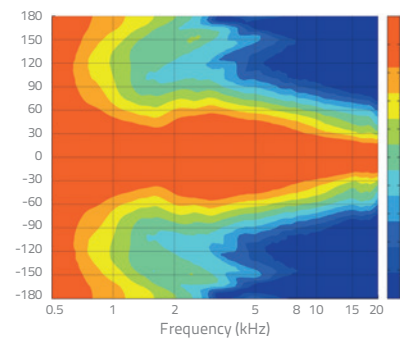
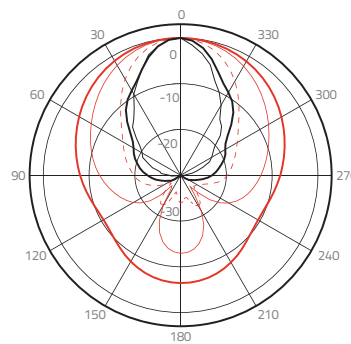

VERTICAL ANGLE*

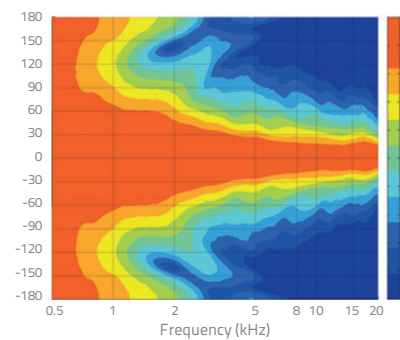
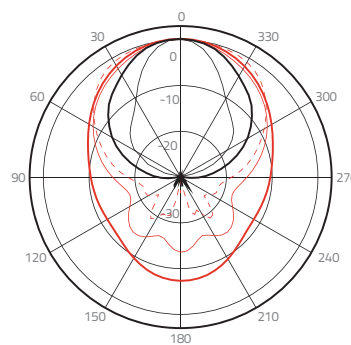

* Horn measured using LAVOCE DN10.17T compression driver

All specifications subject to change without notice_E.a

1 kHz 2 kHz 4 kHz 8 kHz 16 kHz

WWW.LAVOCESPEAKERS.COM



Lavoce Italiana

sales@lavocespeakers.com sales.cn@lavocespeakers.com