

WAF102.50A

Lavoce

10" WOOFER

FERRITE MAGNET
ALUMINIUM BASKET DRIVER



- 2.5 INCH EDGEWOUND CCA VOICE COIL
- 98,5 dB/SPL SENSITIVITY
- 500 WATT PROGRAM POWER HANDLING
- FEM OPTIMIZED MOTOR AND SUSPENSIONS
- OPTIMIZED COOLING SYSTEM

GENERAL SPECIFICATIONS

Nominal diameter	mm (in.)	250 (10)
Nominal impedance	Ω	8
Minimum impedance	Ω	6,5
Program power (1)	W	500
AES Power rating (2)	W	250
Sensitivity (3)	dB	98,5
Frequency range	Hz	70 ÷ 4000
Voice coil diameter	mm (in.)	65 (2.5)
Chassis material	Aluminium	
Magnet material	Ferrite	
Magnet dimensions OD x ID x h	mm (in.)	155 x 80 x 20 (6.1 x 3.15 x 0.79)
Coil material	Edgewound CCA	
Former material	Glass Fiber	
Cone material	Water Resistant Treated Paper + Water Proof Front Side Treatment	
Surround material	Polycotton	
Xmax (4)	mm (in.)	5 (0.2)
Xmech (5)	mm (in.)	9 (0.35)
Gap height	mm (in.)	8 (0.31)
Voice coil winding height	mm (in.)	14 (0.55)
Driver displacement volume	l (ft ³)	1,5 (0.05)
Recommended enclosure	l (ft ³)	39 (1.38)
Recommended tuning	Hz	70

FREQUENCY RESPONSE AND IMPEDANCE

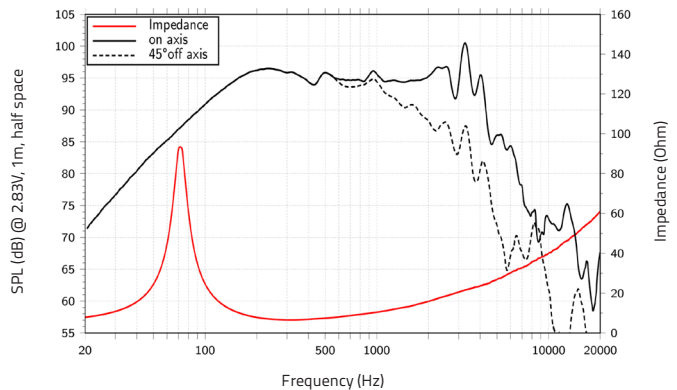

DIMENSIONS mm (in.)

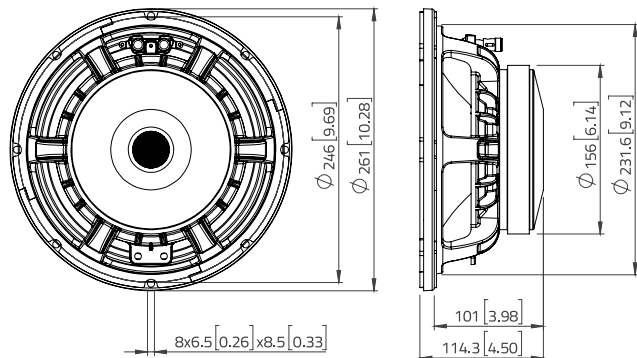

SMALL SIGNAL PARAMETERS

DC resistance	Re	Ohm	5,5
Resonance frequency	Fs	Hz	71
Moving mass	Mms	g (oz)	34,6 (1.22)
Compliance	Cms	mm/N	0,142
Force factor	BxL	N/A	16,1
Mechanical Q-factor	Qms		5,371
Electrical Q-factor	Qes		0,33
Total Q-factor	Qts		0,31
Equivalent air volume	Vas	l (ft ³)	29,09 (1.03)
Voice coil Inductance	Le	mH	0,82
Diaphragm area	Sd	cm ² (in. ²)	380,1 (58.9)
Reference efficiency	Eta 0	%	3,10
Efficiency bandwidth product	EBP	Hz	215

SHIPPING INFORMATION

Net weight	kg (lb.)	4,7 (10.2)
Multipack size (1)	mm (in.)	300 x 300 x 148 (11.8 x 11.8 x 5.8)
Multipack weight	kg (lb.)	5,6 (12.3)

(1) Program power is defined as 3 dB greater than AES Power. (2) Tested for two hours using a continuous, band-limited pink noise signal as per AES 2-1984 Rev. 2003. Loudspeaker tested in free air. (3) From T/S parameters, measured with Klippel DA LPM module. (4) The Xmax is calculated as: $(Hvc - Hg)/2 + Hg/4$. Hvc is the voice coil height and Hg the gap height. (5) The Xmech is calculated as: $(Hvc - Hg)/2 + (Hg - 2)$. Hvc is the voice coil height and Hg the gap height. (6) Thiele-Small parameters are measured after preconditioning: a) at 20°C - 22°C, 50% humidity for 2 hours; b) by Klippel LSI measurement.

All specifications subject to change without notice_E.a

WWW.LAVOCESPEAKERS.COM



Lavoce Italiana

sales@lavocespeakers.com sales.cn@lavocespeakers.com