

FANE EN21501 2x 15" FULL RANGE ENCLOSURE

FANE COMPONENT OPTIONS

SOVEREIGN PRO 15-600LF | 15" Bass Driver

SOVERIGN PRO 15-500 | 15" Bass Driver

CD-150 | 1" Compression Driver

ELH003 | Fane Horn Flare

WWW.FANE-INTERNATIONAL.COM



FANE EN21501

2x 15" SUB BASS ENCLOSURE

Hints and Tips

CHOICE OF TIMBER

We recommend multi-layer 18mm Birch plywood as the best material to withstand the rigours of intensive 'life on the road' or likely exposure to damp conditions. Alternatively, 18mm Medium Density Fibreboard (MDF) offers good acoustic properties with the advantage of being less expensive (although heavier), and may be used where the cabinet will be permanently installed in a dry environment. Both materials accept any type of paint finish extremely well.

CONSTRUCTION TECHNIQUE

All joints should be totally airtight, liberally glued with PVA adhesive and screwed at 200mm (8") centres with 4.2mm or 4.8mm (No.8 or No.10) x 50 mm (2") self-tapping screws. The bracing panels are designed to ensure rigidity of construction, making the cabinet as free as possible from panel resonances caused by the internal forces generated by the loudspeaker drive unit and resulting in unwanted vibration and colouration of the sound. Again, these joints should be glued and screwed using the same method.

PORTING

The length and area of the ports as specified in the drawing should be strictly adhered to.

ACOUSTIC INSULATION

To aid panel damping and prevent internal reflections and standing waves, all internal panels of the cabinet (with the exception of the front baffle) should be lagged with acoustically absorptive material. We recommend the use of acoustic foam wadding. This should be glued, stapled or tacked to the inside of the cabinet, taking care to ensure that port tubes are not obstructed.

CROSSOVER NETWORK

Superb performance can be achieved when used with appropriately matched custom designed passive crossover networks. The recommended Fane crossover network components should be mounted as far away as practical from the magnets. Major damage to both the crossover and drive units could result should the board become loose during transit, therefore the crossover should be mounted firmly to an inside wall of the cabinet, ideally secured using self-tapping screws in screw cups to reduce the pressure exerted on the circuit board, and spaced with rubber grommets between the circuit board and cabinet wall. It must however be pointed out that due to the very high power handling capabilities of these drive units, some users may wish to employ an active crossover in order to utilise the full potential of these drivers.

INTERNAL WIRING

Wiring should be kept away from moving loudspeaker parts and fastened to internal panelling to avoid buzzing. We encourage the use of colour coded wiring to identify polarity (red for +ve and black for -ve), and recommend carrying out a phase check before first using the cabinet. This is achieved by applying the positive terminal of a battery to the positive cabinet input which should result in the speaker cone moving forwards if in phase (or by using a dedicated polarity checker).

DRIVE UNIT FIXING

The drive unit should be front mounted to the baffle using T-nuts and fixing bolts, and is supplied with a length of self adhesive foam sealing strip which should be fitted around the front edge of the speaker cut-outs to guarantee airtight conditions.

LOUDSPEAKER PROTECTION

The exposed front of all speaker drive units is of course vulnerable to damage, necessitating some means of protection which must be robust but acoustically transparent. Cloth/foam type grilles are feasible for fixed cabinets, but a metal mesh grille is certainly the preferred and superior option. It is recommended that a foam gasket material is used between the wooden cabinet and the metal grille to prevent any unwanted resonances. Please contact Penn Elcom at www.penn-elcom.com to discuss their standard and custom speaker grill solutions.

CABINET HARDWARE

We specify Penn-Elcom hardware products as recommended components in the construction of FANE-loaded cabinets. Please visit www.penn-elcom.com to view the full range of Penn Elcom products and discuss standard and custom hardware solutions.

CABINET FINISHING

Cabinet finishing is largely a matter of personal preference and as such, detail of this is omitted from the drawing. Generally cabinets are either painted or covered in carpet or vinyl material. If a carpet material is chosen it is recommended that a very dense tight pile type is used and that metal corner protectors are fitted. Corner protectors will have a defined radius that the edges of the cabinet should be finished to. The cabinet shown on the first page of this document has all the external edges routed with a 13mm radius and coated in a hard wearing textured epoxy paint. Two steel carrying handles have been fitted. There are various types of handles and terminal panels available and again details of these have been omitted. It is recommended that these be purchased and cutouts be made in an appropriate position in the panels before final build. Be aware that handles and terminals are not necessarily airtight, which will be detrimental to performance but can be easily remedied using a silicone sealant or polyurethane mastic to seal all joints. Contact Penn Elcom at www.penn-elcom.com to discuss their spray coating, carpet and vinyl options.

WARNING!

There are safety regulations regarding the installation of loudspeaker systems. This document is intended as a guide to construct a suitable acoustic enclosure for our components. Fane Acoustics can hold no responsibility for the structural integrity of the finished system. The system will be no stronger than the material it is made from and the joinery techniques used to assemble it. Suspending the finished system will require additional hanging hardware. There are companies who specialise in the manufacture and correct use of this hardware. They are experts and must be consulted if overhead suspension of the finished system is intended.

FANE INTERNATIONAL LTD.

Sovereign House

Gilcar Way

Wakefield Europort

Castleford WF10 5QS

United Kingdom

Tel: +44 (0)1924 224618

Fax: +44 (0)1924 899166

Email: info@fane-international.com

www.fane-international.com

Fane International Ltd operates a policy of continuous product development and reserves the right to change specification at any time without notice. Any specifications or product images in this document are correct at the time of print. © 2011, Fane International Ltd.

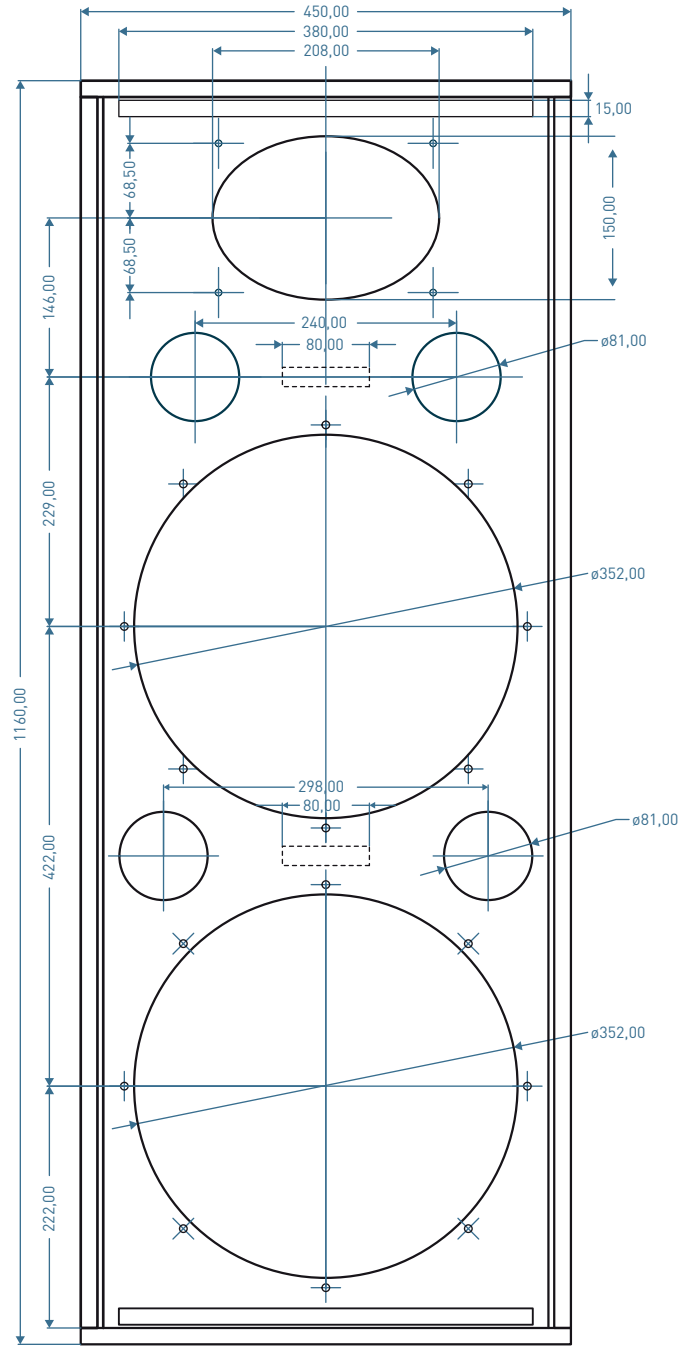
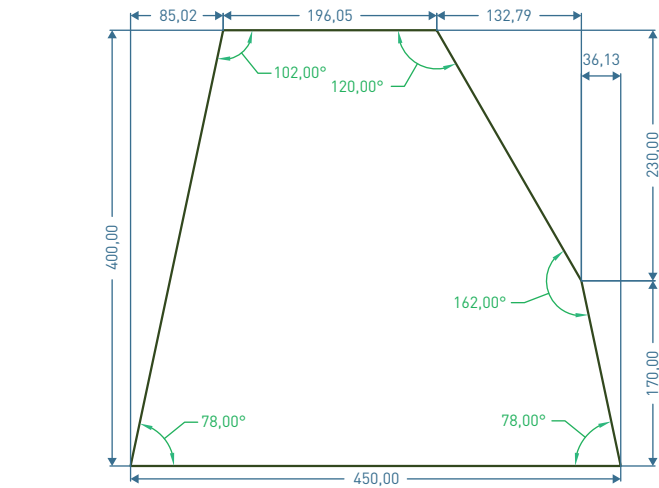
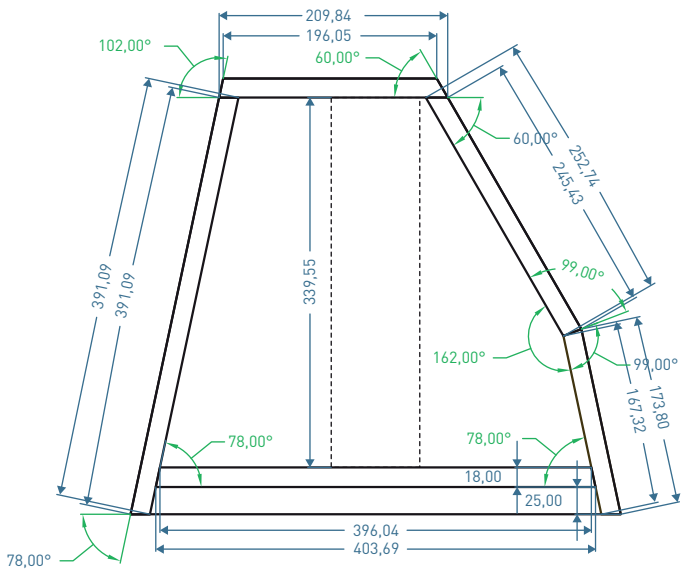

MODEL			
FANE EN21501 - 2x 15" FULL RANGE ENCLOSURE			
REVISION	SCALE	UNITS	Tolerance Linear +/- 0.4, Holes +0.1/-0.0, None - Cumulative
1.0	1:1	mm	
MATERIAL / FINISH			
Unspecified material. 15mm Birch Plywood, Baffle 18mm MDF			

THE PROFESSIONAL SERIES SOVEREIGN PRO 15-600LF

BASS DRIVER



15" / 381 mm CHASSIS DIAMETER	600 w (A.E.S.) POWER HANDLING	98 dB SENSITIVITY (1w / 1m)
35 Hz - 3.5 kHz FREQUENCY RESPONSE	3.0" / 76.2 mm COPPER VOICE COIL	

The Sovereign Pro 15-600LF is intended for use in two-way ported enclosures, such as the classic bass driver plus horn tweeter or compression driver format. The unit features a die cast chassis with long throw motor system and long throw surround allowing solid bass reproduction at high-power levels. The driver exhibits a smooth frequency response to give a balanced tonal characteristic when properly matched to appropriate high-frequency drivers. The Sovereign Pro 15-600LF can also be used in ported bass enclosures to deliver tight accurate bass down to 40 Hz. The unit features a 3-inch voice coil with a power handling of 600 Watts and an average sensitivity of 98 dB.

- Highly versatile in 2-way ported enclosures.
- Smooth frequency response.
- Delivers tight accurate bass down to 40 Hz.
- UK manufactured cone with optimised pulp offering increased strength, durability and performance.

THE PROFESSIONAL SERIES

FREQUENCY RESPONSE DATA*

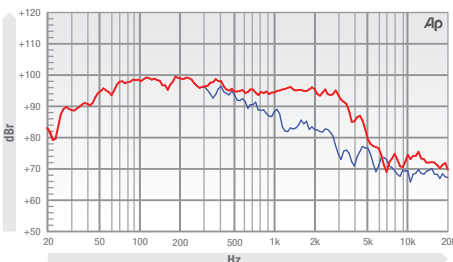

IMPEDANCE

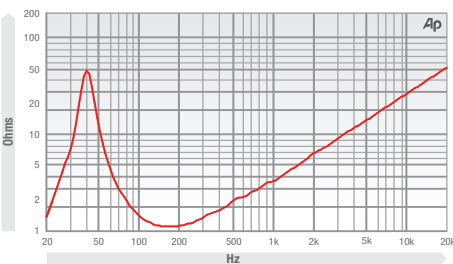

PREDICTED BASS RESPONSE

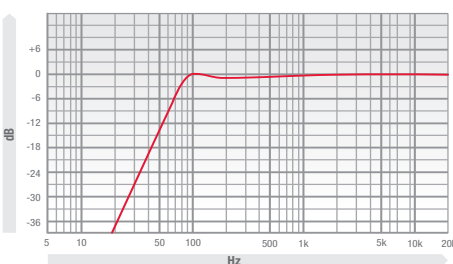

ELECTRO ACOUSTIC SPECIFICATIONS

Nominal Chassis Diameter	15" / 381 mm
Impedance	8 Ω
Power Handling	600 w (A.E.S.)
Peak Power (6dB Crest Factor)	2400 w (A.E.S.)
Usable Frequency Range -6dB	35 Hz - 3.5 kHz
Sensitivity (1 w - 1 m)	98 dB
Moving Mass inc. Air Load	89 grams
Minimum Impedance Zmin	6.5 Ω
Effective Piston Diameter	13.03" / 330.96 mm
Peak Displacement Volume of Cone Vd	0.59 litres
Magnet Weight	100 oz
Magnetic Gap Depth	0.39" / 10 mm
Flux Density	1.1 Tesla
Coil Winding Height	0.75" / 19 mm
Voice Coil Diameter	3.0" / 76.2 mm

MOUNTING / SHIPPING INFORMATION

Overall Diameter	16" / 406.4 mm
Width Across Flats	15.25" / 387.35 mm
Flange Height	0.30" / 7.62 mm
Baffle Hole Diameter F/M	13.85" / 351.79 mm
Baffle Hole Diameter R/M	14" / 355.6 mm
Gasket Supplied	Front & Rear
Fixing Holes	4x 0.281" diam on 15.5 PCD / 8 x 0.281 diam on 14.56 PCD 4x 7.1 mm diam on 393.7 PCD / 8x 7.1 diam on 370 PCD
Depth	6.85" / 174 mm
Weight	20.49 lb / 9.3 kg
Recommended Enclosure Volume	2.64 - 5.29 cu ft / 75 - 150 litres
Shipping Weight	23.03 lb / 10.45 kg
Packing Carton Dimensions	220 x 420 x 420 mm

THIELE SMALL PARAMETERS

FS Hz	40 Hz
RE Ohms	6.5 Ω
Qms	8.8
Qes	0.38
Qts	0.37
Vas Ltr	188 litres
Vd litres	0.59 litres
CMS (mm/N)	0.18 mm/N
BL T/m	19.7 T/m
Mms (grams)	89 grams
Xmax (mm)	6.9 mm
Sd (cm²)	856 cm²
Efficiency %	3.05%
Le (1k Hz)	1.85 mH

MATERIALS OF CONSTRUCTION

Former Material	Glass Fibre
Voice Coil	Copper
Magnet Material	Ferrite
Chassis	Die-cast Aluminium
Cone	Curvilinear Paper
Surround / Edge Termination	Polyvinyl Damped Multi Roll. Poly Cotton
Dust Dome	Paper
Connectors	Push-button Spring Terminals
Polarity	Positive voltage at red terminal causes forward motion of cone

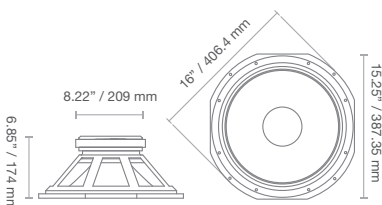

- Please enquire about alternative impedances.
- A.E.S. power handling test. Pink noise bandpass filtered at 12 dB per octave with cutoff frequencies of 40 Hz and 400 Hz. Driver mounted in free air, test signal applied at rated power for two hours.
- Please note that the frequency response measurements are supplied for comparison only and are not a measure of the low frequency performance which may be achieved in a fully optimised system.

SOVEREIGN PRO 15-600LF



THE PROFESSIONAL SERIES SOVEREIGN PRO 15-500

BASS DRIVER

15" / 381 mm
CHASSIS DIAMETER

500 w (A.E.S.)
POWER HANDLING

99 dB
SENSITIVITY (1w / 1m)

42 Hz - 3.5 kHz
FREQUENCY RESPONSE

3.0" / 76.2 mm
COPPER VOICE COIL

Designed for use in 75-
150 litre enclosures

The Sovereign Pro 15-500 is intended for use in two-way ported enclosures, such as the classic bass driver plus horn tweeter or compression driver format. The unit features a die cast chassis with long throw motor system and high linearity suspension allowing solid bass reproduction at high-power levels. The driver exhibits smooth frequency response to give a balanced tonal characteristic when properly matched to appropriate high-frequency drivers. The Sovereign Pro 15-500 is designed for use in 75 to 150 litre ported enclosures. The unit features a 3-inch voice coil with a power handling of 500 Watts and an average sensitivity of 99dB.

- Highly versatile in 2-way ported enclosures.
- High SPL producing fast and punchy bass.
- Smooth extended frequency response.
- High linearity suspension.
- UK manufactured cone with optimised pulp offering increased strength, durability and performance.

FREQUENCY RESPONSE DATA*

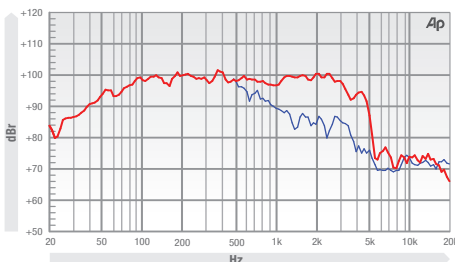

IMPEDANCE

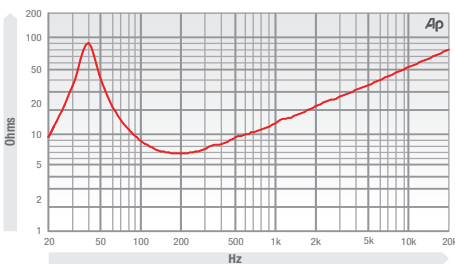

PREDICTED BASS RESPONSE

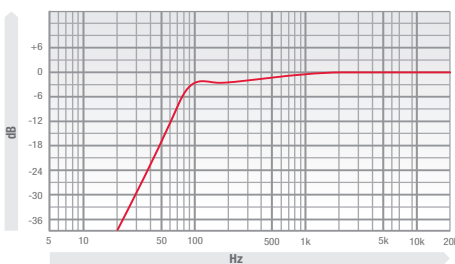

ELECTRO ACOUSTIC SPECIFICATIONS

Nominal Chassis Diameter	15" / 381 mm
Impedance	4 / 8 / 16 Ω
Power Handling	500 w (A.E.S.)
Peak Power (6dB Crest Factor)	2000 w (A.E.S.)
Usable Frequency Range -6dB	42 Hz - 3.5 kHz
Sensitivity (1 w - 1 m)	99 dB
Moving Mass inc. Air Load	85 grams
Minimum Impedance Zmin	6.5 Ω
Effective Piston Diameter	13.03" / 330.96 mm
Peak Displacement Volume of Cone Vd	0.51 litres
Magnet Weight	80 oz
Magnetic Gap Depth	0.39" / 10 mm
Flux Density	1.0 Tesla
Coil Winding Height	0.70" / 18 mm
Voice Coil Diameter	3.0" / 76.2 mm

MOUNTING / SHIPPING INFORMATION

Overall Diameter	16" / 406.4 mm
Width Across Flats	15.25" / 387.35 mm
Flange Height	0.30" / 7.62 mm
Baffle Hole Diameter F/M	13.85" / 351.79 mm
Baffle Hole Diameter R/M	14" / 355.6 mm
Gasket Supplied	Front & Rear
Fixing Holes	4x 0.281" diam on 15.5 PCD / 8 x 0.281 diam on 14.56 PCD 4x 7.1 mm diam on 393.7 PCD / 8x 7.1 diam on 370 PCD
Depth	6.37" / 162 mm
Weight	17.52 lb / 7.95 kg
Recommended Enclosure Volume	2.64 - 5.29 cu ft / 75 - 150 litres
Shipping Weight	20.05 lb / 9.1 kg
Packing Carton Dimensions	220 x 420 x 420 mm

THIELE SMALL PARAMETERS

FS Hz	40 Hz
RE Ohms	5.4 Ω
Qms	10
Qes	0.33
Qts	0.32
Vas Ltr	192 litres
Vd litres	0.513 litres
CMS (mm/N)	0.186 mm/N
BL T/m	18.9 T/m
Mms (grams)	85 grams
Xmax (mm)	6 mm
Sd (cm²)	855 cm²
Efficiency %	3.60%
Le (1k Hz)	1.9 mH

MATERIALS OF CONSTRUCTION

Former Material	Glass Fibre
Voice Coil	Copper
Magnet Material	Ferrite
Chassis	Die-cast Aluminium
Cone	Curvilinear Paper
Surround / Edge Termination	Polyvinyl Damped Multi Roll. Poly Cotton
Dust Dome	Solid Paper
Connectors	Push-button Spring Terminals
Polarity	Positive voltage at red terminal causes forward motion of cone

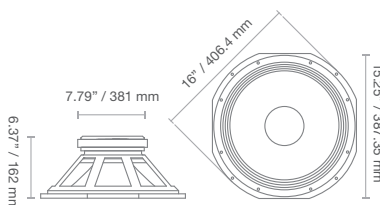

- Please enquire about alternative impedances.
- A.E.S. power handling test. Pink noise bandpass filtered at 12 dB per octave with cutoff frequencies of 40 Hz and 400 Hz. Driver mounted in free air, test signal applied at rated power for two hours.
- Please note that the frequency response measurements are supplied for comparison only and are not a measure of the low frequency performance which may be achieved in a fully optimised system.



THE HIGH FREQUENCY DEVICES SERIES CD-150

COMPRESSION DRIVER

1" / 25.4 mm
SOUND CHANNEL / THROAT SIZE

50 w (A.E.S.)
POWER HANDLING

106 dB
SENSITIVITY (1w / 1m)

2 kHz - 18 kHz
FREQUENCY RESPONSE

1.75" / 44 mm
Aluminium Voice Coil

The CD150 is an excellent choice for professionals who are looking to achieve high sound pressure level performance and clarity of sound. The unit combines high BL and a lightweight diaphragm assembly to produce a very high output device that also features extended bandwidth and well defined frequency response. The CD150 is optimised for high performance multi-way system designs. The driver has a rated low frequency response limit of 2.2 kHz and features extended response to 20kHz. The ferrite based permanent magnetic system produces a very high efficiency to weight and size ratio. The compression driver exit diameter and fixings are an industry standard and will match to commercially available high frequency horns. This makes the CD150 ideal for high level professional touring applications as well as high level fixed installation.

- 1" exit ferrite magnet compression driver.
- 1.75" / 43mm copper clad aluminium voice coil.
- Titanium diaphragm with double sinusoidal roll surround (titanium).
- 50 Wrms (AES standard)
- Copper inductance ring for extended response.
- Ferrofluid cooled
- Also available for OEMs with an aluminium diaphragm option.

FREQUENCY RESPONSE DATA*

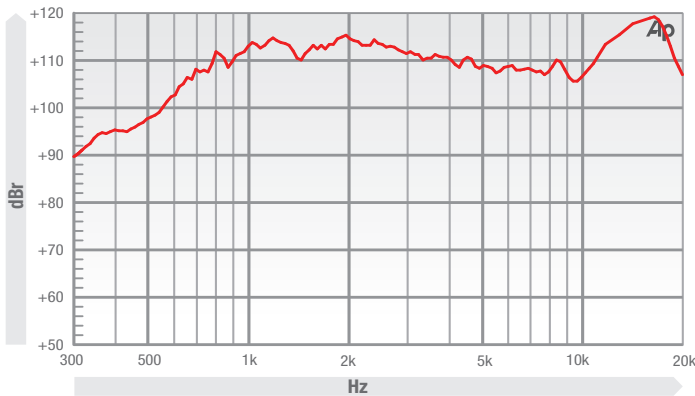

IMPEDANCE

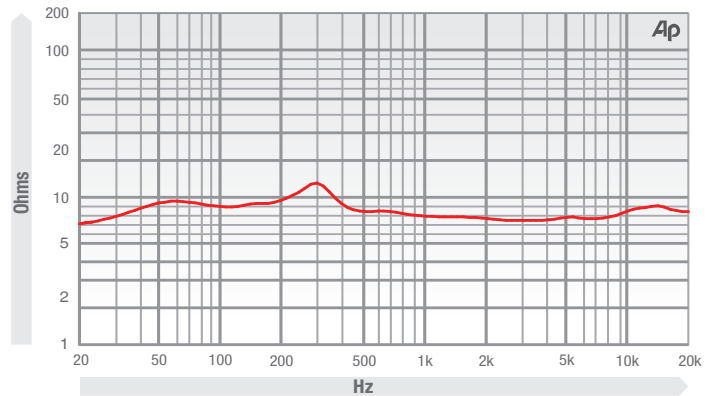

ELECTRO ACOUSTIC SPECIFICATIONS		MOUNTING / SHIPPING INFORMATION		MATERIALS OF CONSTRUCTION	
Sound Channel / Throat Size	1" / 25.4 mm	Overall Diameter	5.27" / 133.85 mm	Coil Former	Polyamide
Nominal Impedance	8 / 16 Ω	Depth	2.48" / 63 mm	Voice Coil Material	Aluminium
Power Handling	50 w (A.E.S.)	Weight	6.5 lb / 2.97 kg	Diaphragm Material	Titanium
Sensitivity (1 w - 1 m)	106 dB	Shipping Weight	6.8 lb / 3.1 kg	Surround / Edge Termination	Double Sinusoidal Roll Titanium
Usable Frequency Range -6dB	2 kHz - 18 kHz	Packing Carton Dimensions	150 x 160 x 180 mm	Magnet Material	Ferrite
Recommended Crossover Frequency Filtered at 18dB / Octave	3.5 kHz	Bolt Fixing Hole Dimensions & Qty	2x M6 on 72.2 mm - 3" PCD	Connectors	4.8 mm Spade
Effective Diaphragm Diameter	1.75" / 44 mm			Polarity	Positive voltage at red/ positive terminal causes positive pressure at throat exit
Voice Coil Diameter	1.75" / 44 mm				
Voice Coil DC Resistance	6.2 / 10.5 Ω				
Max Diaphragm Displacement	0.016" / 0.4 mm				
Flux Density	1.65 Tesla				
Magnet Weight	39 oz				

* Please enquire about alternative impedances.
* Frequency response measurement taken on axis with 1w signal at distance of 1m using custom horn with 90° x 40° coverage.



FANE EN21501

ADDITIONAL COMPONENTS

ELH-003

- Eliptic Horn Nominal Directivity
80° x 60°
- Loading down to 1000 Hz
- Strong Glass Fibre material
- Perfectly Controlled Dispersion



ELECTRO ACOUSTIC SPECIFICATIONS

Sound Channel / Throat Size	1" / 25.4 mm
Nominal Coverage (-6dB)	80 x 60
Cut-off Frequency	1000 Hz
Material	Glass fibre resin

ELECTRO ACOUSTIC SPECIFICATIONS

Sound Channel / Throat Size	1" / 25.4 mm
Nominal Coverage (-6dB)	80 x 60
Cut-off Frequency	1000 Hz
Material	Glass fibre resin

MOUNTING / SHIPPING INFORMATION

Overall Dimensions	240 x 180 mm
Baffle Cut Out	Minor Rad. 75 mm Major Rad. 104 mm
Total Depth	115.5 mm
Fixing Holes	4 x 6 mm holes 101/76 mm
Net Weight	0.9 kg
Shipping weight	1.3 kg

FREQUENCY RESPONSE DATA

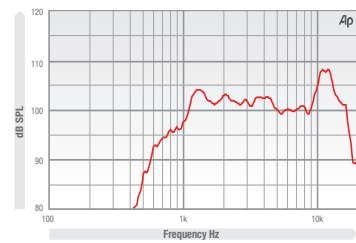

Frequency response curve of the horn measured on axis at distance of 1 meter with 1 watt signal with CD-140 compression driver.

PENN - M1702 PORT TUBE (x4)

ELECTRO ACOUSTIC SPECIFICATIONS

Diameter	75 mm / 2.95"
Material	Plastic
Finish	Black
Weight	0.058 Kg / 0.13 lb



FANE CROSSOVER EN21501

