



FC-185ND01

SUB BASS DRIVER

18" / 457.2 mm
CHASSIS DIAMETER

2400 W
PROGRAM POWER

30 Hz - 2 kHz
FREQUENCY RESPONSE

5" / 127 mm
VOICE COIL

98.5 dB
SENSITIVITY (1W/ 1m)

12 mm Xmax
MAXIMUM LINEAR EXCURSION

- + New, vented cast aluminium chassis design.
- + Lightweight and efficient neodymium motor system generates minimal flux modulation.
- + Aluminium core heat sink and large motor venting provides reduced power compression and effective temperature regulation.
- + Long driver excursion. Peak to peak travel of 52mm.
- + High BL factor for controlled, fast and accurate low frequency sound reproduction.
- + Dual 'spaced' suspension system provides increased linearity and control at high levels of excursion.
- + Suitable for bass reflex or horn loaded enclosure designs.
- + 5-Inch Copper voice coil.

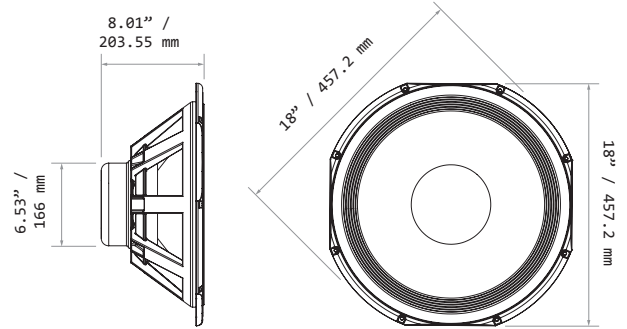

GENERAL SPECIFICATIONS

Nominal Chassis Diameter	18" / 457.2 mm
Nominal Impedance ⁽¹⁾	8 Ohm
Minimum Impedance Zmin	6.5 Ω
AES Power Handling ⁽²⁾	1200 W (A.E.S.)
Program Power	2400 W
Peak Power (6dB Crest Factor)	4800 W
Frequency Range (-6dB)	30 Hz - 2 kHz
Sensitivity (1W/ 1m)	98.5 dB
Magnet Material	Neodymium
Magnet Weight	- oz
Magnetic Gap Depth	0.47" / 12 mm
Flux Density	1.2 Tesla
Former Material	Glass Fibre
Voice Coil Material	Copper
Coil Winding Height	1.1" / 28 mm
Voice Coil Diameter	5" / 127 mm
Cone/ Dust Dome Material	Paper / Paper
Surround / Edge Termination	Polyvinyl Damped Multi Roll. Poly Cotton

TECHNICAL & THIELE SMALL PARAMETERS

Fs	33 Hz
Re	5.6 Ω
Qms	17.7
Qes	0.3
Qts	0.295
Vas	203 Litres
Vd	1.35 Litres
Cms	0.106 mm/N
Bl	29.4 T/m
Mms	220 g
Xmax	12 mm
Sd	1164 cm ²
Efficiency	2.4 %
Le (1k Hz)	2.76 mH
EBP	110 Hz
Effective Piston Diameter	15.68" / 398.27mm
Rec. Enclosure Volume	60 - 230 Litres

MOUNTING / SHIPPING INFORMATION

Overall Diameter	18" / 457.2 mm
Width Across Flats	18" / 457.2 mm
Depth	8.01" / 203.55 mm
Flange Height	0.465" / 11.8 mm
Baffle Hole Diameter F/M	16.53" / 419.86 mm
Baffle Hole Diameter R/M	16.33" / 414.78 mm
Chassis Material	Die-cast Aluminium
Gasket Supplied	Front
Outer Fixing Holes	8x ø 7 mm on 468 mm PCD
Inner Fixing Holes	8x ø 7 mm on 438.15 mm PCD
Connectors ⁽⁴⁾	Push-button Spring Terminals
Weight	25.35 lb / 11.5 Kg
Shipping Weight	25.5 lb / 11.57 Kg
Packing Carton Dimensions (mm)	(W) 485 (D) 485 (H) 230

FREQUENCY RESPONSE DATA⁽³⁾

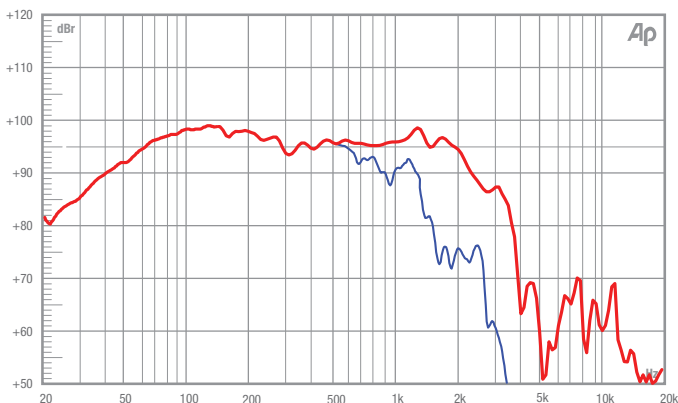

IMPEDANCE

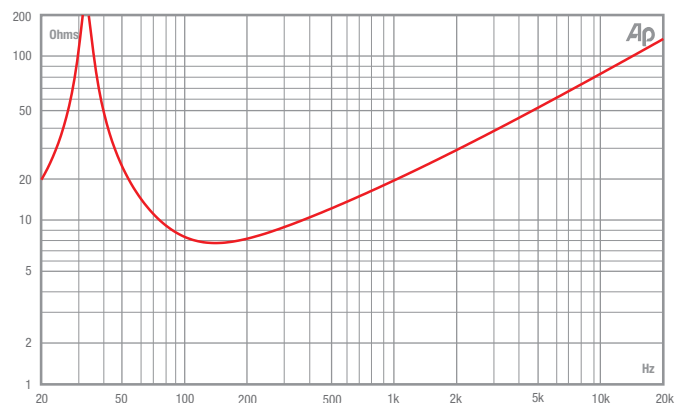

(1) Please enquire about alternative impedances.

(2) A.E.S. power handling test. Pink noise bandpass filtered at 12 dB per octave with cutoff frequencies of 35 Hz and 350Hz. Driver mounted in free air, test signal applied at rated power for two hours.

(3) Half space response measured in a 975 Litre sealed box. Blue line = fundamental 45° off-axis. Please note that the frequency response measurements are supplied for comparison only and are not a measure of the low frequency performance which may be achieved in a fully optimised system.

(4) Positive voltage at red terminal causes forward motion of cone.