

15DS100

4Ω**LF Drivers - 15.0 Inches**

- 3000 W continuous program power capacity
- 100 mm (4 in) four layer aluminium voice coil
- 39 - 1000 Hz response
- 96.8 dB sensitivity
- Double silicone spider with optimized compliance
- Ventilated voice coil gap for reduced power compression
- Aluminium demodulating ring for very low distortion

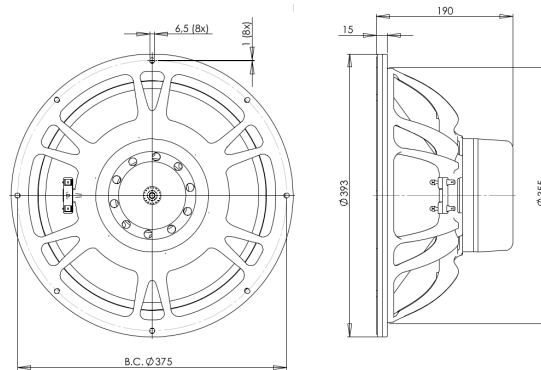

This next evolution subwoofer uses a new, longer, four layer aluminum voice coil. The result is less heat, more energy in the gap, higher sensitivity, higher power handling, lower distortion and better overall performance. The 15DS100 features a 37mm long, 4 inch diameter (100mm) Copper Clad Aluminum Wire voice coil. With a 1500watt AES power rating, 96.8 dB sensitivity, and over 14.0mm of Xvar, this high energy subwoofer is a significant step forward from similar models in the B&C range.

15DS100

LF Drivers- 15.0 Inches

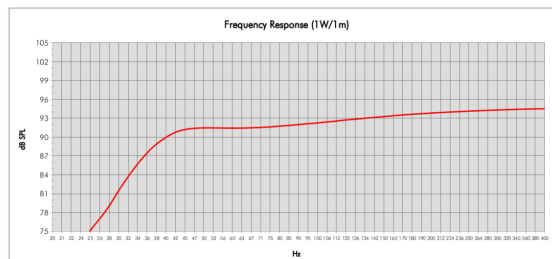
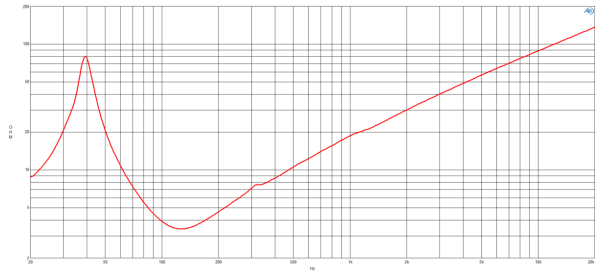
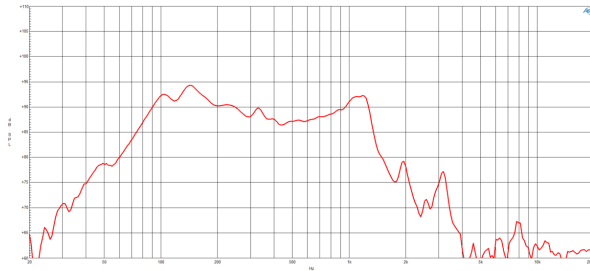

Model: **15DS100**
 Enclosure Type: **Bas Reflex** Configuration: **One Driver**
 Internal Port Volume (litre): **120** CB: **3**
 Tuning Frequency (Hz): **40** Port Area (cm²): **300.0**
 Frequency (-3 dB) (Hz): **-** Port Length (cm): **29.9**
 Frequency (-10 dB) (Hz): **33.1**

SPECIFICATIONS

Nominal Diameter	380 mm (15.0 in)
Nominal Impedance	4 Ω
Minimum Impedance	3.4 Ω
Nominal Power Handling ¹	1500 W
Continuous power handling ²	3000 W
Sensitivity (1W/1m) ³	96.8 dB
Frequency Range	39 - 1000 Hz
Voice Coil Diameter	100 mm (4.0 in)
Winding Material	Aluminium
Former Material	Glass Fibre
Winding Depth	34.0 mm (1.34 in)
Magnetic Gap Depth	16.0 mm (0.63 in)
Flux Density	0.7 T

DESIGN

Surround Shape	Triple Roll
Cone Shape	Radial
Magnet Material	Neodymium Inside Slug
Spider	Double Silicone
Pole Design	T-Pole
Woofers Cone Treatment	TWP Waterproof Both Sides
Recommended Enclosure	120.0 dm ³ (4.24 ft ³)
Recommended Tuning	40 Hz

PARAMETERS⁴

Resonance Frequency	39 Hz
Re	2.4 Ω
Qes	0.23
Qms	8.16
Qts	0.23
Vas	73.0 dm ³ (2.58 ft ³)
Sd	855.0 cm ² (132.53 in ²)
η _o	1.8 %
Xmax	± 13.0 mm
Xvar	± 14.0 mm
Mms	233.0 g
Bl	24.3 Txm
Le	2.8 mH
EBP	169 Hz

MOUNTING AND SHIPPING INFO

Overall Diameter	393 mm (15.47 in)
Bolt Circle Diameter	374 mm (16.7 in)
Baffle Cutout Diameter	353.0 mm (13.9 in)
Depth	190 mm (7.5 in)
Flange and Gasket Thickness	16 mm (0.63 in)
Air Volume Occupied by Driver	6.0 dm ³ (0.21 ft ³)
Net Weight	9.6 kg (21.16 lb)
Shipping Units	1
Shipping Weight	10.9 kg (24.03 lb)
Shipping Box	425x425x224 mm (16.73x16.73x8.82 in)

SERVICE KIT

Recone kit	RCK15DS1004
------------	-------------

B&C Speakers s.p.a.

Via Poggiomoro, 1 - Loc. Vallina, 50012 Bagno a Ripoli (FI) - ITALY - Tel. +39 055 65721 - Fax +39 055 6572312 - mail@bcspeakers.com

1. 2 hours test made with continuous pink noise signal within the range F_s - $10F_s$. Power calculated on rated minimum impedance. Loudspeaker in free air.
2. Power on Continuous Program is defined as 3 dB greater than the Nominal rating.
3. Applied RMS Voltage is set to 2 V for 4 ohms Nominal Impedance.
4. Thiele-Small parameters are measured after a high level 20 Hz sine wave preconditioning test.